

Shuttle Probe

The Shuttle Probe is a unique and convenient process probe for monitoring liquid samples, *in-situ*. Rugged, reliable, and easy to use, it is ideal for continuous process monitoring applications where it is difficult and/or costly to shut down the line for probe servicing or where side streams or fast loops are not appropriate. The probe is mounted in a standard size process flange for easy installation. Periodic probe cleaning and referencing can be performed without interrupting the process flow. The Shuttle Probe matches perfectly to any Guided Wave dual-beam spectrophotometer.

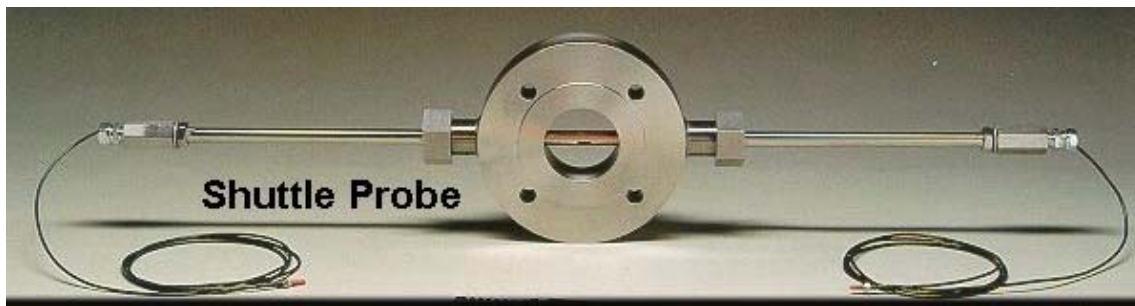

Unique Operation

Guided Wave's Shuttle Probe consists of two transmission probes connected by a threaded, precision-machined coupler that also functions to accurately set a fixed and reproducible pathlength. After coupling, the two transmission probes become a one-piece sensor that is inserted through the heart of a durable process flange. Carefully engineered gland seals prevent process leakage thus facilitating safe operation. The area where the light interacts with the sample, the sample path, can be easily removed from or "shuttled" out of the process by firm but gentle tugs on either end of the probe. By design the forces are balanced resulting in a negligible ejection force on the probe. Thus the critical cleaning of the optical windows and subsequent probe referencing are possible without having to interrupt the process.

Process-Resistant Construction

The Shuttle Probe is designed to withstand most process conditions. The body of the probe is built from 316 stainless steel or -- by special order -- other corrosion resistant materials. The probe's sapphire optical windows are sealed to the probe body using a proprietary gold alloy braze technology. These materials are unaffected by most hydrocarbons and polymers. The threads of the precision coupler that determine the probe's pathlength and maintain the optical alignment are protected by a double o-ring set. This prevents process material from entering the threaded area and seizing the coupler in place. The process seals are hydraulic style chevron packing glands, doubled for safety. The fiber connection area is conduit-ready and sealed to prevent moisture infiltration into the back end of the probe.

Wide Operating Range

The Shuttle Probe is designed to operate over a range of temperatures and pressures up to the limits imposed by the Class 150 or 300 flange and the gland seal material, typically Teflon™. This probe halves are available in four standard lengths: 8", 12", 18", and 24" (other lengths are available by special order). The pathlength is determined by the coupler which is available in many standard sizes from 1 to 62 mm. Custom paths are also available.

High Light Transmission

Like all Guided Wave probes, the Shuttle Probe provides exceptional optical performance. Typical transmission is 38% averaged over all wavelengths in the 800 to 1600 nm region. That means more signal, lower measurement noise and lower limits of detection. Of course, the Shuttle Probe's optics are permanently aligned at the factory. There is no need for any optical adjustments in the field. Nor any chance for optical misalignment to occur under normal processing conditions or during servicing.

Matched to Guided Wave Analyzers

The probe, or sample interface, is a crucial component of a complete analyzer system. For optimal performance, the probe must be "optically matched" with the spectrophotometer and with the optical fiber that transmits the spectral data. The Shuttle Probe (and each of Guided Wave's other probes) are matched to Guided Wave's analyzers and fiber to achieve the highest possible performance.

Specifications

Probe Lengths (inches):	8; 12; 18; 24; (custom lengths available on request)
Pathlength (mm ± 0.10 mm):	1; 2; 3; 3.5; 5; 10; 12; 15; 20; 25; 37; 50; 62 (custom lengths available on request)
Probe Diameter (inches):	0.625 [15.9 mm]
Spectral Range:	UV-VIS (200 – 600 nm); VIS-NIR (380 – 1100 nm); NIR (800 – 2100 nm)
Optics:	Fused silica (UV-VIS); BK7 (VIS-NIR and NIR)
Fiber Diameter (µm)	200; 300; 400; 500; 600
Fiber Connectors:	SMA 905 standard; (FC and ST on request)
Fiber Types:	High-OH (UV-VIS); Low-OH or Ultra Low-OH (VIS-NIR)
Optical Efficiency (%T):	> 18% from 800 nm to 1600 nm
Temperature Range:	-20 °C to 260 °C (probe only) {Maximum handle temperature 50°C}
Pressure Range:	0 psi to 2000 psi [0 – 138 bar] (probe only)
Body Material:	SS316 standard (SS304, SS316L, Hastelloy, Monel, Titanium, and Nickel available on request)
Window Material:	Sapphire
Window Seal:	Au alloy braze
Flange Sizes:	1-½"; 2" 3" Class 150 and Class 300
Flange Ratings	Temperature and pressure per ASME/ANSI B16.5 1988

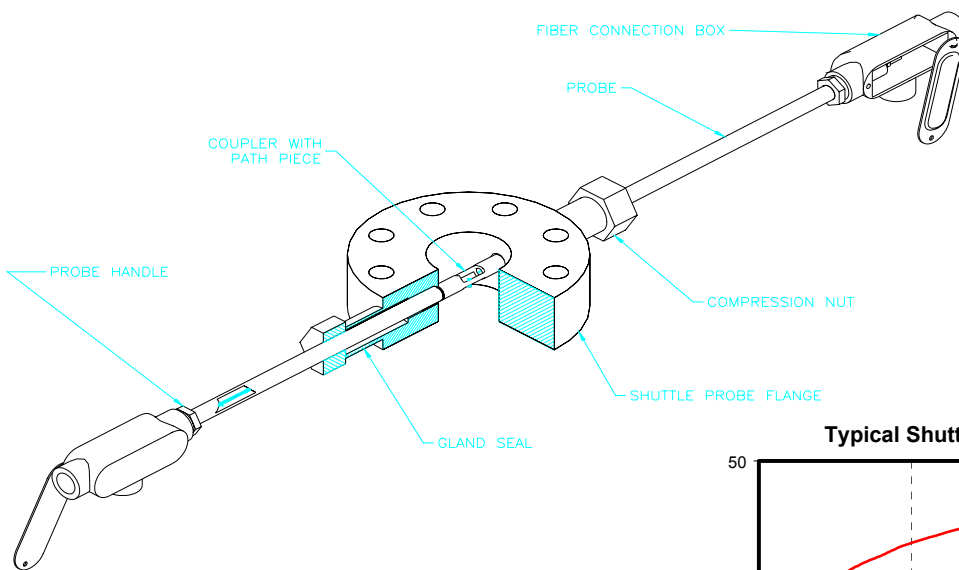

For specific dimensions and installation details, please contact Guided Wave at gwinfo@guided-wave.com or visit our web site at <http://www.guided-wave.com> to view our other process probes, process analyzers, and fiber products.

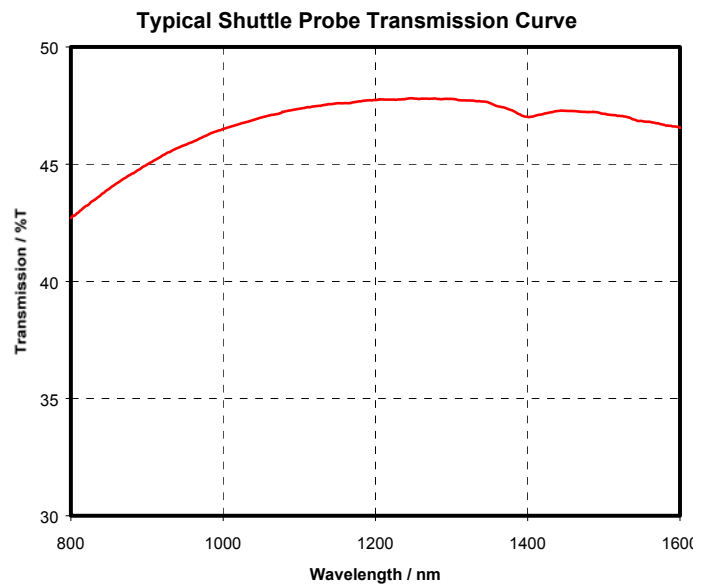

Specifications are subject to change without notice.
 ©2004 Guided Wave Inc.
 Literature Number: 1020-05-09 RevA3

Guided Wave Incorporated
 3033 Gold Canal Drive
 Rancho Cordova, CA 95670
 USA
 Tel: 916.638.4944; Fax: 916.635.8458
gwinfo@guided-wave.com

www.guided-wave.com

Guided Wave BV
 PO Box 427
 7550 AK Hengelo (o)
 The Netherlands
 Tel: +31.74.2595390; Fax: +31.74.2595752
info@guided-wave-europe.com