

## Model 412 Process Analyzer

The Guided Wave Model 412 process Analyzer offers remote *multi-channel* near-infrared (NIR) or visible (Vis) spectroscopic scanning and analysis. Essentially a *smart chemical sensor*, the Model 412 provides exceptional signal-to-noise, excellent wavelength stability, NIST traceable wavelength calibration, dual-beam optics and built-in diagnostics. Process operators, engineers, and researchers will appreciate the Model 412's ability to monitor up to 12 process streams (or points within a stream) with accuracy, repeatability, and reliability.

### Complete Analyzer System

The Model 412 is the core of a comprehensive process analyzer system that includes the spectrophotometer; one or more NIR probes, fiber optic cables, and intelligent scanning-and-analysis software. Like other Guided Wave spectrophotometers, the Model 412 uses near-infrared radiation to collect spectral data from liquids, gases, slurries, glass, and polymer-based films. The spectral data are interpreted by the analyzer system's software, to determine the composition and/or physical characteristics of the material.

### Real-Time Measurements

In remote spectroscopy the analyzer transmits radiation to one or more probes installed directly in your process reactors or pipes. Readings can be made at any time, providing *real-time process information*. The Guided Wave Model 412 is designed to be used with Guided Wave's single-strand fiber optic cable. This patented cable contains a high-efficiency glass fiber, permitting transmission distances of up to several hundred meters.

### True Multiplexing

The Model 412 also features Guided Wave's patented, integrated multiplexer. This multiplexer; together with appropriate light input modules, permits the Model 412 to monitor up to twelve probes simultaneously greatly *reducing the cost per measurement point*. You can also purchase the Model 412 as a three-channel instrument, then upgrade it later to 6, 9, or 12 channels.

### Research-Grade Signal-to-Noise Ratio

The Model 412's *dual-beam design*, coupled with its high output scanning grating, puts more light in the fiber; providing the highest available signal-to-noise ratio. Every Model 412 also



provides excellent wavelength accuracy (NIST traceable) and superb wavelength repeatability.

### Designed For On-Line Processes

The Guided Wave Model 412 is suitable for on-line analyses of most processes and process streams. Three versions of the Model 412 are available. The Vis version operates at 380 - 1070 nm and uses a silicon detector (Si). The NIR version uses an Indium-Gallium-Arsenide (InGaAs) detector and operates at 800-1700 nm. The extended, or xNIR, version uses an extended-range InGaAs detector and operates at 1000-2100 nm.

Here are just a few of the many applications for which our customers rely on the Model 412 every day:

- On-line analyses of polyols: OH and acid number
- On-line analyses of polymers: reaction endpoint, co-polymer ratio
- On-line analyses of films: color; thickness, %T, %R
- On-line measurement of moisture content
- On-line analyses of refinery products
- On-line analyses of vinyls: solvent composition
- Process research and development

## Specifications

Model	412 Vis	412 NIR	412 xNIR
Wavelength Range (rated)	380 - 1070 nm	800 - 1700 nm	1000 - 2100 nm
Wavelength Range (optimal)	400 - 1000 nm	900 - 1600 nm	1050 - 2000 nm
Wavelength Accuracy	±0.28 nm	±0.20 nm	±0.20 nm
Wavelength Repeatability	±0.02 nm	±0.02 nm	±0.02 nm
Wavelength Stability (rms/24hrs)	±0.05 nm	±0.05 nm	±0.05 nm
Minimum Step Size	0.2 nm	0.2 nm	0.2 nm
Spectral Resolution	3.2 nm	6.8 nm	6.8 nm
Photometric rms Noise	< 20 µAU	< 13 µAU	< 26 µAU
Photometric (Baseline) Stability (rms/24hrs)	< 1 mAU	< 1 mAU	< 1 mAU
Dynamic Range (Mid Range)	4.0 decades	4.0 decades	4.0 decades
Optical Connections	SMA 905; 500 µm Diameter Single Strand Fiber Optic Cable		
Data Communications	RS422, RS-232 (DB9 Null Modem Cable), or optical fiber modem		
Dimensions	30" (w) x 17.3" (d) x 41.3" (h) [76 cm x 44 cm x 105 cm]		
Weight	200 lbs [91 kg]		
Power	1500 W, 110/220 Vac, 50/60 Hz		
Climate (Temperature/Humidity)	0 °C to 40 °C Shaded/0 - 100% Condensing		
Certification	CE		

### Included as Standard Equipment

- CLASS-PA™ or SpectrOn™ process analysis software
- Integrated opto 22 I/O Panel w/16 slots
- Optical jumper cables and tool kit with torque wrench
- Temperature controlled NEMA 4 (IP66) Enclosure

### Options

- Camo *Unscramble*™ chemometrics software for Windows™
- Model Studio interface to *Unscramble*™

### Enclosure Options

The Guided Wave Model 412 comes installed with an air-cooled internal climate control system for General Purpose Environments NEMA 4 (IP66). This instrument can also be packaged for hazardous environments. These options include Class I Division 2 Groups C & D T2A, Class I Division 1 Groups C & D T3, and ATEX EEx pdem [ib] II C T4.

### Instrument Control Unit (Host Computer)

The Model 412 must be used with an Instrument Control Unit (a PC/AT-compatible computer) that meets or exceeds the following specification: Pentium Processor; 200 MHz or faster; 128 MB DRAM, SVGA graphics, hard drive (2 GB or greater), floppy disk drive (3.5"/1.44 MB) and CD-ROM, or Windows XP SP3.

### Operating Environment

- Internal operating temperature settable between 30 and 40 °C controlled to ± 1 °C of set point
- External (ambient) temperature 0-40 °C, shaded location
- Temperature limits for constant operation ± 10 °C
- External humidity (condensing) 0-100%

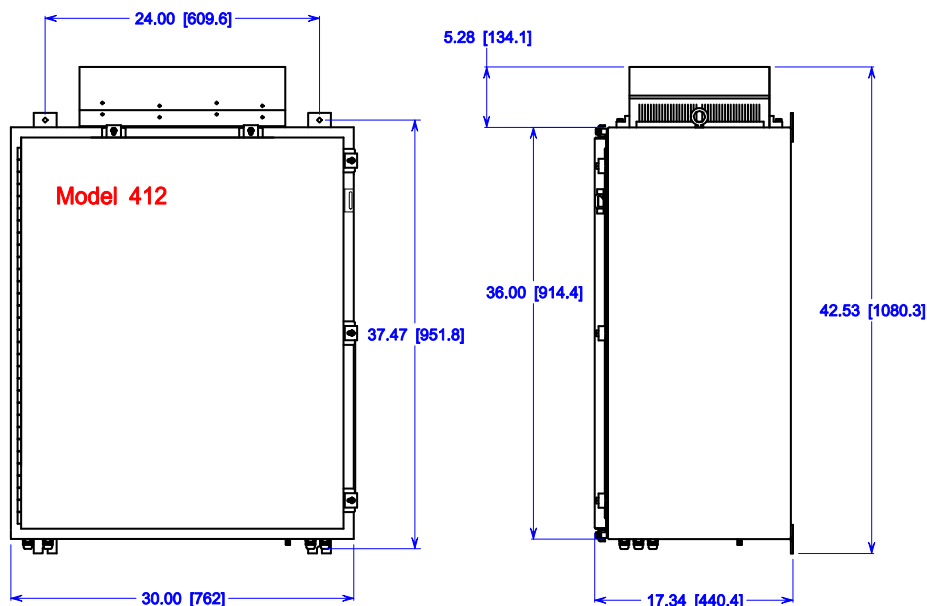

For more information on Guided Wave analyzers and probes, contact: [gwinfo@guided-wave.com](mailto:gwinfo@guided-wave.com) or visit our web site at: <http://www.guided-wave.com>.

*Specifications are subject to change without notice.*

©2004 Guided Wave Inc.  
Literature Number: 1013-05-09 RevA6

## Guided Wave Incorporated

3033 Gold Canal Drive  
Rancho Cordova, CA 95670  
USA  
Tel: 916.638.4944; Fax: 916.635.8458  
[gwinfo@guided-wave.com](mailto:gwinfo@guided-wave.com)

[www.guided-wave.com](http://www.guided-wave.com)

## Guided Wave BVBA

Leo de Béthunelaan 105/0001  
9300 Aalst  
Belgium  
Tel: +32-53-631165; Fax: +32-53-631696  
[gwinfo@guided-wave.com](mailto:gwinfo@guided-wave.com)