

ChemViewMX SMART™ Photometer

ChemViewMx expands our ChemView® SMART Photometer technology at up to 8 sample points. We do this by adding a fiber optic multiplexer.

The operator can send a contact closure command to advance the ChemViewMx to the next sample point position. One of the 6 4- 20 mA analog outputs responds with the current sample location (4 mA = position 1; 6 mA = position 2, etc.) so the process computer always know which sample point is currently being examined.

In a process photometer, there is no need for calibration transfer between the sample channels. Each channel is zeroed, for example, with a clean, dry insertion probe or flow cell. Once the absorbances are zeroed, the sample is analyzed, the coefficients are applied and the chemistry is determined. A schematic of ChemViewMx is shown below.

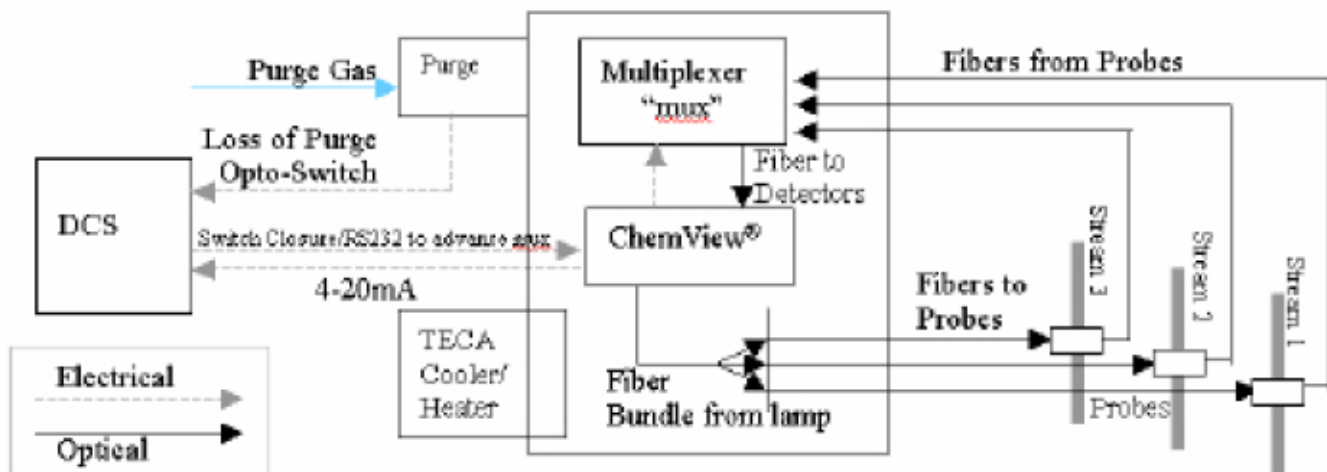

ChemViewMX SMART™ Photometer

A bundle of fibers from the lamp is separated into individual fibers on a plate within ChemViewMx. Each optical connection, up to 8, is used to connect the ChemViewMx to a separate probe or flow cell at a unique sample point. The returning fiber from the probe at that sample point comes back into ChemViewMx to the fiber optic multiplexer. Light from this fiber is directed back into the ChemView for analysis. It is a sequential procedure that you control via contact closure or RS232 signal. An internal optic within the multiplexer module rotates to the next sample point and the process is repeated.

As shown in the picture and schematic, the 36 x 36 x 12" enclosure can be purged and temperature controlled for best ChemView performance. The software within ChemViewMx is identical to that in ChemView, except you will see "Probe 1", "Probe 2", etc depending upon which sample point is being analyzed.



ChemViewMX 4, 6 or 8 Sample Points

MEASUREMENT MODE	
ACID NO.	29
HYDROX	57
H2O PPM	2800
REF VOLT	5800
Probe 2 – REACTOR 3	
CONF	DIAG
ADJ	ABS

Different probes and different wavelengths can be used at each sample point, realizing that they can only be selected from the 5 analytical wavelengths and 1 reference wavelength. The calibrations are independent.



ChemViewMX SMART™ Photometer

Specifications

Enclosures	Class 1, Div. 1,2, Groups B-D (Z- or X-purge) Fiberglass
Dimensions	36 x 36 x 12"; 100 lbs
Certifications	C1D1 NFPA 496, 1993, FM compliant
Purges	Expo-Safety Systems, non-metallic continuous flow subminiPurge. Intrinsically safe switch closure and pneumatic "winkie" fo purge loss. 1/2" NPTF purge fitting. Purge vent orifice is Size 1 (for 0.4 cfm; 10 L/min). Allow 6 min. purge cycle (min. 4 volumes) prior to power up
Purge Gas	110 p.s.i. clean, dry compressed air or inert gas
Fiber Connections	SMA 905 400 - 600 micron (core)
Detectors	Max. 5 analyzing and 1 reference <ul style="list-style-type: none"> •Si for 250-950 nm •InGaAs for 900-1650 nm •TE-Cooled extended InGaAs for 1000-2150nm
Filters	10 nm FWHM for UV/VIS, 15 nm for NIR typical. 4 OD out-of-band blocking
Light Source	<ul style="list-style-type: none"> •Optical Solutions brand StabLamp, optical feedback circuit, Tungsten-halogen bulb, precision mounting for easy replacement. Approx 8 months bulb life nominal •Pulsed Xe lamp for UV/VIS. Approx 2 year bulb life
Wavelength Drift	0.1 nm with Si detector 0.2 nm near 1450 nm with InGaAs detector
Photometric Drift	<2 mAU with $\pm 5^{\circ}\text{C}$ variation (± 2 to 3 mAU with Xe) 0.2 mAU/ $^{\circ}\text{C}$ at 0 AU typical <2 mAU over 2 weeks
Photometric	<1 mAU (3 mAU with Xe source)
Outputs	4 4-20 mA isolated, self-powered. 2 4-20 mAU additionally optional for a total of 6
Environmental	10 - 40 $^{\circ}\text{C}$, 10-90% rel. humidity (non-condensing)
Power	110 - 240 V AC, 50-60 Hz, 70 VA (24 V DC, 2.1 A)
Multiplexing	4, 6 or 8 sample points
Sample Selection	Contact closure or RS232 ASCII (1,2....8)

Guided Wave Incorporated
 3033 Gold Canal Drive
 Rancho Cordova, CA 95670
 Tel: 916-638-4944
 Fax: 916-635-8458
 gwinfo@guided-wave.com

www.guided-wave.com

Literature: 1035-06-11

Guided Wave BV
 PO Box 427
 7550 AK Hengelo (o)
 The Netherlands
 Tel: +31.74.2595390
 Fax: +31.74.2595752
 info@guided-wave-europe.com